

Bauderer Packaging LLC

775 W. Beldon Ave, Suite A, Addison, IL 60101
Rob Knuepfer, President

Date: November 20, 2023

Application Facts:

Industry	Manufacturing
NAICS	561900
Type of App	New
Location	Clark County
RDA	LVGEA, Perry Ursem

Company Profile

Bauderer Packaging, LLC (Bauderer) plans to establish a new production facility in North Las Vegas. Bauderer is a co-packer that packages its client's products with the utmost quality, speed, and care. Bauderer is a newly created division of Contract Packaging Associates, with a primary focus on food packaging. The new southern Nevada facility will be a co-packing operation consisting of 2-3 canister filling lines of snack products for a major CPG manufacturer. The company delivers design, manufacturing, and custom contract packaging solutions from blue chip consumer brands to small start-ups. The company also offers logistical warehousing benefits and has food warehousing capabilities such as temperature-controlled storage and packaging supplies. Due to clean, protected and allergen-controlled food rooms the company is able to handle products of any kind. The company will provide excellent benefits to its employees, be a solid community partner and strive to be an employer of choice. Bauderer is open to partnering with community colleges and other educational institutions in the area that may have students interested in manufacturing related opportunities, internships, etc and plans to use local Nevada businesses for its production and shop supplies, repair services, and other business related needs. *Source: Bauderer Packaging, LLC*

Tax Abatement Requirements:

	<u>Statutory</u>	<u>Company Application</u>	<u>Meeting Requirements</u>
Job Creation	50	89	Yes
Average Wage	\$29.28	\$29.33	Yes
Equipment Capex (SU & MBT)	\$1,000,000	\$13,025,000	Yes
Equipment Capex (PP)	\$5,000,000		

Additional Requirements:

Health Insurance	65%	71%	Yes
Revenues generated outside NV	51%	100%	Yes
Business License	<input type="checkbox"/> Current	<input type="checkbox"/> Pending	<input checked="" type="checkbox"/> Will comply

Total Tax Liability (without tax abatements)

Direct (company)
\$1,744,068

Total
\$11,427,256

Tax Abatements

Contract Terms

Estimated Tax Abatement

Sales Tax Abmt.	2% for 2 years	\$830,344
Modified Business Tax Abmt.	50% for 4 years	\$97,200
Personal Property Tax Abmt.	50% for 10 years	\$479,875
Total Estimated Tax Abatement over 10 yrs.		\$1,407,419

Net New Tax Revenues

Direct

Indirect

Taxes after Abatements

Local Taxes

Property	\$810,874	\$4,279,631	\$5,090,505
Sales	\$70,125	\$2,222,537	\$2,292,662
Lodging	\$0	\$120,203	\$120,203

State Taxes

Property	\$44,350	\$249,011	\$293,361
Sales	\$282,500	\$741,773	\$1,024,273
Modified Business	\$494,962	\$665,253	\$1,160,215
Lodging	\$0	\$38,618	\$38,618
Total Estimated New Tax Revenue over 10 yrs.	\$1,702,811	\$8,317,026	\$10,019,837

Economic Impact over 10 yrs.

Economic

Construction

Total

Total Jobs Supported	208	16	224
Total Payroll Supported	\$119,640,807	\$1,091,868	\$120,732,675
Total Economic Value	\$592,167,853	\$3,146,424	\$595,314,277

IMPORTANT TERMS & INFORMATION

Tax Abatements are reduction or discount of tax liability and companies do not receive any form of payment.

Total Estimated Tax Abatement is a tax reduction estimate. This estimated amount will be discounted from total tax liability.

Estimated New Tax Revenue is amount of tax revenues local and state government will collect after the abatement was given to applying company.

Economic Impact is economic effect or benefits that this company and it's operations will have on the community and state economy measured by total number of jobs, payroll and created output.



September 29, 2023

Mr. Tom Burns
Executive Director
Nevada Governor's Office of Economic Development
555 E. Washington Avenue, Suite 5400
Las Vegas, Nevada 89101

Dear Mr. Burns,

Bauderer Packaging LLC (herein known as "Bauderer") is applying to the State of Nevada for the Sales and Use, Modified Business, and Personal Property Tax Abatements. We request their application be placed on the agenda for the November 2023 GOED Board Meeting.

Bauderer is exploring their options to locate manufacturing operations in Southern Nevada and hire 89 new employees. These new hires will make an average hourly wage of \$29.33 and be provided with a comprehensive benefits package. Bauderer will make a total capital investment of \$15 million over the next two years.

Our team has reviewed Bauderer's application and found it to comply with Nevada's statutory requirements for tax abatements. This application has the full support and endorsement of the Las Vegas Global Economic Alliance. Thank you for your consideration.

Sincerely,

A handwritten signature in blue ink that reads 'Perry Ursem'. The signature is fluid and cursive, with a long horizontal stroke at the end.

Perry Ursem
Senior Vice President of Business Development

Enclosure

September 21, 2023

Mr. Tom Burns
Executive Director
Nevada Governor's Office of Economic Development
555 E. Washington, Suite 5400
Las Vegas, NV 89101

Dear Mr. Burns:

By way of this letter and the attached application, Bauderer Packaging LLC is requesting tax incentives to assist with our relocation efforts. Recent strategic planning has our company focused on creating a presence in Nevada. A significant part of this consideration is the economic incentives offered by the state. We are projecting to add 89 full-time employees with an average wage of \$29.33 / hour over the next two years of operations.

A brief history of our company along with an overview of our products is included with our submission. To summarize -- our company was formed in April, 2016 as a food co-packer with four (4) production rooms. After successful startup of operations and with continual reinvestment in the business, we have expanded to ten (10) production rooms and now service major CPG companies. We wish to expand our business to Nevada in support of growth opportunities for these customers.

The economic development incentives offered by the State of Nevada have been an integral factor in our relocation strategy. The projected cost savings from the support of these incentives will allow Bauderer Packaging to hire a greater number of full time employees, supporting the Governor's initiative for providing more Nevada residents with long term work and career opportunities. Additionally, Nevada's pro-business climate provides Bauderer Packaging with a sustainable location for ongoing strategic growth. We are projecting to occupy 200,000 sq. ft. in Nevada, with capital equipment investment approximating \$13,025,000 dollars for a total capital investment of \$15,025,000.

Our experience with representatives from the Las Vegas Global Economic Alliance has been positive and we look forward to your approval in supporting our expansion efforts. Thank you for your time and consideration.

Sincerely,

BAUDERER PACKAGING, LLC



Robert Knuepfer
President

Enclosures

708.990.6704
baudererpackaging.com

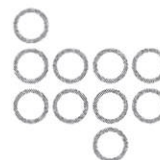

Mayor
Pamela A. Goynes-Brown

Council Members
Isaac E. Barron
Ruth Garcia-Anderson
Scott Black
Richard J. Cherchio



City Manager
Ryann Juden, J.D., Ph.D.

Economic Development and Redevelopment

2250 Las Vegas Boulevard, North · Suite 920 · North Las Vegas, Nevada 89030
Telephone: (702) 633-1523 · Fax: (702) 633-7164 · TDD: (800) 326-6868
www.cityofnorthlasvegas.com

October 9, 2023

Thomas Burns
Executive Director
Nevada Governor's Office of Economic Development
555 E. Washington, Suite 5400
Las Vegas, NV 89101

Dear Director Burns:

The City of North Las Vegas is in full support of Bauderer Packaging, LLC, and their incentive application to be reviewed by the GOED Board at their next scheduled meeting.

I am pleased that after a multi-state search, Bauderer Packaging, LLC, has identified an approximately 200,000 square foot facility within our city. Bauderer Packaging capital investment projections are forecasting approximately \$15,025,000 and will employ a team of 89 full-time employees with an average hourly wage of \$29.33.

It is my pleasure to support their application and welcome Bauderer Packaging, LLC to the North Las Vegas business community.

A handwritten signature in blue ink, appearing to be "JL", is located below the text.

Jared Luke
Director of Government Affairs and Economic Development

ECONOMIC DEVELOPMENT

Incentive Application

Company is an / a: (check one)

New location in Nevada

Expansion of a Nevada company

Company Name: Bauderer Packaging LLC

Date of Application: September 29, 2023

Section 1 - Type of Incentives

Please check all that the company is applying for on this application:

- Sales & Use Tax Abatement
- Modified Business Tax Abatement
- Personal Property Tax Abatement
- Recycling Real Property Tax Abatement
- Other: _____

Section 2 - Corporate Information

COMPANY NAME (Legal name under which business will be transacted in Nevada) Bauderer Packaging LLC		FEDERAL TAX ID # 38-3990061	
CORPORATE ADDRESS IL	CITY / TOWN	STATE / PROVINCE	ZIP 60101
MAILING ADDRESS TO RECEIVE DOCUMENTS (If different from above)	CITY / TOWN	STATE / PROVINCE	ZIP
TELEPHONE NUMBER 708/865-2028	WEBSITE www.baudererpackaging.com		
COMPANY CONTACT NAME Rob Knuepfer	COMPANY CONTACT TITLE President		
E-MAIL ADDRESS robert@baudererpackaging.com	PREFERRED PHONE NUMBER 708/865-2028		

Has your company ever applied and been approved for incentives available by the Governor's Office of Economic Development? Yes No

If Yes, list the program awarded, date of approval, and status of the accounts (attach separate sheet if necessary):

Section 3 - Program Requirements

Please check two of the boxes below; the company must meet at least two of the three program requirements:

- A capital investment of \$1,000,000 in eligible equipment in urban areas or \$250,000 in eligible equipment in rural areas are required. This criteria is businesses. In cases of expanding businesses, the capital investment must equal at least 20% of the value of the tangible property owned by the business.
- New businesses locating in urban areas require fifty (50) or more permanent, full-time employees on its payroll by the eighth calendar quarter following quarter in which the abatement becomes effective. In rural areas, the requirement is ten (10) or more. For an expansion, the business must increase the employees on its payroll by 10% more than its existing employees prior to expansion, or by 25 (urban) or 6 (rural) employees, whichever is greater.
- In both urban and rural areas, the average hourly wage that will be paid by the business to its new employees is at least 100% of the average statewide hourly wage.

Note: Criteria is different depending on whether the business is in a county where the population is 100,000 or more or a city where the population is 60,000 or more "urban" area), or if the business is in a county where the population is less than 100,000 or a city where the population is less than 60,000 (i.e., "rural" area).

Section 4 - Nevada Facility

Type of Facility:

- Headquarters
- Technology
- Back Office Operations
- Research & Development / Intellectual Property
- Service Provider
- Distribution / Fulfillment
- Manufacturing
- Other: _____

PERCENTAGE OF REVENUE GENERATED BY THE NEW JOBS CONTAINED IN THIS APPLICATION FROM OUTSIDE NEVADA 100%	EXPECTED DATE OF NEW / EXPANDED OPERATIONS (MONTH / YEAR) August, 2024		
NAICS CODE / SIC 561900	INDUSTRY TYPE Manufacturing		
DESCRIPTION OF COMPANY'S NEVADA OPERATIONS Co-packing operation consisting of 2-3 canister filling lines of snack products for a major CPG manufacturer.			
PROPOSED / ACTUAL NEVADA FACILITY ADDRESS Golden Triangle Logistics Center; Bldg 4; 2815 E. Washburn Road	CITY / TOWN North Las Vegas	COUNTY Clark County	ZIP 89081
WHAT OTHER STATES / REGIONS / CITIES ARE BEING CONSIDERED FOR YOUR COMPANY'S RELOCATION / EXPANSION / STARTUP? Phoenix, AZ and Rancho Cucamonga, CA			

Section 5 - Complete Forms (see additional tabs at the bottom of this sheet for each form listed below)

Check the applicable box when form has been completed.

- 5 (A) Equipment List
- 5 (B) Employment Schedule
- 5 (C) Evaluation of Health Plan, with supporting documents to show the employer paid portion of plan meets the minimum of 65%.
- 5 (D) Company Information Form

Section 6 - Real Estate & Construction (Fill in either New Operations/Startup or Expansion, not both.)

New Operations / Start Up - Plans Over the Next <u>Ten</u> Years	Expansions - Plans Over the Next <u>10</u> Years
<p>Part 1. Are you currently/planning on leasing space in Nevada? <u>Yes</u></p> <p>If No, skip to Part 2. If Yes, continue below:</p> <p style="padding-left: 40px;">What year(s)? <u>2023-2028</u></p> <p style="padding-left: 40px;">How much space (sq. ft.)? <u>200,188</u></p> <p style="padding-left: 40px;">Annual lease cost of space: <u>\$210,197.40</u></p> <p>Do you plan on making building tenant improvements? <u>Yes</u></p> <p>If No, skip to Part 2. If Yes *, continue below:</p> <p style="padding-left: 40px;">When to make improvements (month, year)? <u>Apr-2024</u></p> <hr style="border-top: 1px dashed black;"/> <p>Part 2. Are you currently/planning on buying an owner occupied facility in Nevada? <u>No</u></p> <p>If No, skip to Part 3. If Yes *, continue below:</p> <p style="padding-left: 40px;">Purchase date, if buying (month, year): _____</p> <p style="padding-left: 40px;">How much space (sq. ft.)? _____</p> <p>Do you plan on making building improvements? _____</p> <p>If No, skip to Part 3. If Yes *, continue below:</p> <p style="padding-left: 40px;">When to make improvements (month, year)? _____</p> <hr style="border-top: 1px dashed black;"/> <p>Part 3. Are you currently/planning on building a build-to-suit facility in Nevada? <u>No</u></p> <p>If Yes *, continue below:</p> <p style="padding-left: 40px;">When to break ground, if building (month, year)? _____</p> <p style="padding-left: 40px;">Estimated completion date, if building (month, year): _____</p> <p style="padding-left: 40px;">How much space (sq. ft.)? _____</p>	<p>Part 1. Are you currently leasing space in Nevada? _____</p> <p>If No, skip to Part 2. If Yes, continue below:</p> <p style="padding-left: 40px;">What year(s)? _____</p> <p style="padding-left: 40px;">How much space (sq. ft.)? _____</p> <p style="padding-left: 40px;">Annual lease cost at current space: _____</p> <p>Due to expansion, will you lease additional space? _____</p> <p>If No, skip to Part 3. If Yes, continue below:</p> <p style="padding-left: 40px;">Expanding at the current facility or a new facility? _____</p> <p style="padding-left: 40px;">What year(s)? _____</p> <p style="padding-left: 40px;">How much expanded space (sq. ft.)? _____</p> <p style="padding-left: 40px;">Annual lease cost of expanded space: _____</p> <p>Do you plan on making building tenant improvements? _____</p> <p>If No, skip to Part 3. If Yes *, continue below:</p> <p style="padding-left: 40px;">When to make improvements (month, year)? _____</p> <hr style="border-top: 1px dashed black;"/> <p>Part 2. Are you currently operating at an owner occupied building in Nevada? _____</p> <p>If No, skip to Part 3. If Yes, continue below:</p> <p style="padding-left: 40px;">How much space (sq. ft.)? _____</p> <p style="padding-left: 40px;">Current assessed value of real property? _____</p> <p>Due to expansion, will you be making building improvements? _____</p> <p>If No, skip to Part 3. If Yes *, continue below:</p> <p style="padding-left: 40px;">When to make improvements (month, year)? _____</p> <hr style="border-top: 1px dashed black;"/> <p>Part 3. Do you plan on building or buying a new facility in Nevada? _____</p> <p>If Yes *, continue below:</p> <p style="padding-left: 40px;">Purchase date, if buying (month, year): _____</p> <p style="padding-left: 40px;">When to break ground, if building (month, year)? _____</p> <p style="padding-left: 40px;">Estimated completion date, if building (month, year): _____</p> <p style="padding-left: 40px;">How much space (sq. ft.)? _____</p>
* Please complete Section 7 - Capital Investment for New Operations / Startup.	* Please complete Section 7 - Capital Investment for Expansions below.

BRIEF DESCRIPTION OF CONSTRUCTION PROJECT AND ITS PROJECTED IMPACT ON THE LOCAL ECONOMY (Attach a separate sheet if necessary):

This project establishes a new production facility for Bauderer Packaging in the North Las Vegas community. It provides opportunity to support a major CPG initiative and creates 90 new jobs. These are mid-level manufacturing positions with growth opportunities for the employees who assume the roles. The company will also provide excellent benefits to the employees; be a solid community partner; as well as strive to be an employer of choice..

Section 7 - Capital Investment (Fill in either New Operations/Startup or Expansion, not both.)

New Operations / Start Up	Expansions
How much capital investment is planned? (Breakout below):	How much capital investment is planned? (Breakout below):
Building Purchase (if buying): _____ Building Costs (if building / making improvements): <u>\$2,000,000</u> Land: <u>\$0</u> Equipment Cost: <u>\$13,025,000</u> Total: <u>\$15,025,000</u>	Building Purchase (if buying): _____ Building Costs (if building / making improvements): _____ Land: _____ Equipment Cost: _____ Total: _____
	Is the equipment purchase for replacement of existing equipment? _____ Current assessed value of personal property in NV: _____ (Must attach the most recent assessment from the County Assessor's Office.)

Section 8 - Employment (Fill in either New Operations/Startup or Expansion, not both.)

New Operations / Start Up	Expansions
How many full-time equivalent (FTE*) employees will be created by the end of the first eighth quarter of new operations?: <u>89</u>	How many full-time equivalent (FTE*) employees will be created by the end of the first eighth quarter of expanded operations?: _____
Average hourly wage of these <u>new</u> employees: <u>\$29.33</u>	Average hourly wage of these <u>new</u> employees: _____
	How many FTE employees prior to expansion?: _____
	Average hourly wage of these <u>existing</u> employees: _____
	Total number of employees after expansion: _____

* FTE represents a permanent employee who works an average of 30 hours per week or more, is eligible for health care coverage, and whose position is a "primary job" as set forth in NAC 360.474.

OTHER COMPENSATION (Check all that apply):

- Overtime
 Merit increases
 Tuition assistance
 Bonus
 PTO / Sick / Vacation
 COLA adjustments
 Retirement Plan / Profit Sharing / 401(k)
 Other: _____

BRIEF DESCRIPTION OF ADDITIONAL COMPENSATION PROGRAMS AND ELIGIBILITY REQUIREMENTS (Attach a separate sheet if necessary):

Bauderer Packaging offers a competitive salary and benefit plan offering to its employees. In addition, Bauderer provides merit increases, bonuses, and training to employees. We also provide a 401(k) plan to our employees with no waiting period.

Section 9 - Employee Health Insurance Benefit Program

Is health insurance for employees and is an option for dependents offered?: Yes (**attach health plan and quote or invoice**) No

Package includes (check all that apply):

- Medical
 Vision
 Dental
 Other: _____

Qualified after (check one):

- Upon employment
 Three months after hire date
 Six months after hire date
 Other: 1 month after hire date

Health Insurance Costs:	Percentage of health insurance premium by (min 65%):
Plan Type: <u>PPO</u>	
Employer Contribution (annual premium per employee): <u>\$6,601.00</u>	Company: <u>71%</u>
Employee Contribution (annual premium per employee): <u>\$2,704.00</u>	Employee: <u>29%</u>
Total Annual Premium: <u>\$9,305.00</u>	

[SIGNATURE PAGE FOLLOWS]

Section 10 - Certification

I, the undersigned, hereby grant to the Governor's Office of Economic Development access to all pertinent and relevant records and documents of the aforementioned company. I understand this requirement is necessary to qualify and to monitor for compliance of all statutory and regulatory provisions pertaining to this application.

Being owner, member, partner, officer or employee with signatory authorization for the company, I do hereby declare that the facts herein stated are true and that all licensing and permitting requirements will be met prior to the commencement of operations. In addition, I and/or the company's legal counsel have reviewed the terms of the GOED Tax Abatement and Incentives Agreement, the company recognizes this agreement is generally not subject to change, and any material revisions have been discussed with GOED in advance of board approval.

Robert Knuepfer
Name of person authorized for signature

Signature

President
Title

September 22, 2023
Date

Nevada Governor's Office of Economic Development
555 E. Washington Ave., Ste 5400 • Las Vegas, Nevada 89101 • 702.486.2700 • (Fax) 702.486.2701 • www.goed.nv.gov

Site Selection Factors

Company Name: Bauderer Packaging LLC

County: Clark

Section I - Site Selection Ratings

Directions: Please rate the select factors by importance to the company's business (1 = very low; 5 = very high). Attach this form to the Incentives Application.

Availability of qualified workforce:	<u>5</u>	Transportation infrastructure:	<u>5</u>
Labor costs:	<u>4</u>	Transportation costs:	<u>4</u>
Real estate availability:	<u>5</u>	State and local tax structure:	<u>5</u>
Real estate costs:	<u>4</u>	State and local incentives:	<u>5</u>
Utility infrastructure:	<u>4</u>	Business permitting & regulatory structure:	<u>5</u>
Utility costs:	<u>4</u>	Access to higher education resources:	<u>3</u>

Please summarize the importance of the abatement program to your decision (please include at least a paragraph summary):

Economic incentives will allow Las Vegas and Nevada to be competitive for the project. They will assist the company in hiring a greater number of full time employees, supporting the Governor's initiative for providing more Nevada residents with long term work and career opportunities and assist the company with the start up costs in the State.

5(B) Employment Schedule

Company Name: Bauderer Packaging LLC

County: Clark

Section 1 - Full-Time Equivalent (FTE) Employees

Directions: Please provide an estimated list of full time employees [columns (a) through (d)] that will be hired and employed by the company by the end of the first eighth quarter of new / expanded operations. For example, if the effective date of new / expanded operations is April 1, 2023, the date would fall in Q2, 2025. The end of the first eighth quarter would be the last day of Q2, 2025 (i.e., June 30, 2025). Attach this form to the Incentives Application. A qualified employee must be employed at the site of a qualified project, scheduled to work an average minimum of 30 per week, if offered coverage under a plan of health insurance provided by his or her employer, is eligible for health care coverage, and whose position of a "primary job" as set forth in NAC 360.474.

Please use the Bureau of Labor Statistics Standard Occupational Classification System (SOC) link to populate section (b): https://www.bls.gov/soc/2018/major_groups.htm#11-0000

(a) New Hire Position Title/Description	(b) Position SOC Code	(c) Number of Positions	(d) Average Hourly Wage	(e) Region Average Hourly Wage	(f) Average Weekly Hours	(g) Annual Wage per Position	(h) Total Annual Wages
General and Operations Managers	11-1021	1	\$115.38	\$60.02	40	\$239,990.40	\$239,990.40
Material Moving Workers, All Other	53-7199	18	\$27.00	\$17.93	40	\$56,160.00	\$1,010,880.00
Machinists	51-4041	36	\$27.00	\$23.96	40	\$56,160.00	\$2,021,760.00
Production Workers, All Other	51-9199	23	\$27.00	\$17.36	40	\$56,160.00	\$1,291,680.00
First-Line Supervisors of Production and Operating Workers	51-1011	1	\$48.08	\$29.54	40	\$100,006.40	\$100,006.40
First-Line Supervisors of Production and Operating Workers	51-1011	1	\$57.69	\$29.54	40	\$119,995.20	\$119,995.20
First-Line Supervisors of Production and Operating Workers	51-1011	3	\$36.06	\$29.54	40	\$75,004.80	\$225,014.40
Billing and Posting Clerks	43-3021	3	\$28.85	\$20.00	40	\$60,008.00	\$180,024.00
Industrial Machinery Mechanics	49-9041	3	\$38.46	\$27.94	40	\$79,996.80	\$239,990.40
TOTAL		89	\$29.33	\$21.75			\$5,429,340.80

Section 2 - Employment Projections

Directions: Please estimate full-time job growth in Section 2, complete columns (b) and (c). These estimates are used for state economic impact and net tax revenue analysis that this agency is required to report. The company will not be required to reach these estimated levels of employment. [Please enter the estimated new full time employees on a year by year basis \(not cumulative\)](#)

(a) Year	(b) Number of New FTE(s)	(c) Average Hourly Wage	(d) Payroll
3-Year	5	\$27.00	\$280,800.00
4-Year	5	\$27.00	\$280,800.00
5-Year	5	\$27.00	\$280,800.00

* Column (e) determines if wage is commensurate to current wage ranges in the region the company plans to locate/is located. For these purposes the mean average hourly wage for the location has been used.

U = Unknown / data set for region is not currently available.

Source: Lighcast™ county wages based on the Bureau of Labor Statistics Occupational Employment and Wage Statistics program and county-level administrative wage data.

5(C) Evaluation of Health Plans Offered by Companies

Company Name: Bauderer Packaging LLC

County: Clark

Total Number of Full-Time Employees: 89

Average Hourly Wage per Employee \$29.33

Average Annual Wage per Employee (implied) \$61,006.40

COST OF HEALTH INSURANCE

Annual Health Insurance Premium Cost: \$9,305.00

Percentage of Premium Covered by:

Company 71%

Employee 29%

HEALTH INSURANCE PLANS:

Base Health Insurance Plan*:

PPO-RPP43323 Traditional BCBS

Deductible - per employee \$ 250

Coinsurance 80% / 60%

Out-of-Pocket Maximum per employee \$ 1,000

Additional Health Insurance Plan*:

Deductible - per employee \$ -

Coinsurance 0% / 0%

Out-of-Pocket Maximum per employee \$ -

Additional Health Insurance Plan*:

Deductible - per employee \$ -

Coinsurance 0% / 0%

Out-of-Pocket Maximum per employee \$ -

*Note: **Please list only "In Network" for deductible and out of the pocket amounts .**

Generalized Criteria for Essential Health Benefits (EHB)

[following requirements outlined in the Affordable Care Act and US Code, including 42 USC Section 18022]

Covered employee's premium not to exceed 9.5% of annual wage 4.4% MMQ

Annual Out-of-Pocket Maximum not to exceed \$9,450 (2024) \$1,000 MMQ

Minimum essential health benefits covered (Company offers PPO):

- (A) Ambulatory patient services
- (B) Emergency services
- (C) Hospitalization
- (D) Maternity and newborn care
- (E) Mental health/substance use disorder/behavioral health treatment
- (F) Prescription drugs
- (G) Rehabilitative and habilitative services and devices
- (H) Laboratory services
- (I) Preventive and wellness services and chronic disease management
- (J) Pediatric services, including oral and vision care

No Annual Limits on Essential Health Benefits

I, the undersigned, hereby declare to the Governor's Office of Economic Development that the facts herein stated are true, and that I have attached a qualified plan with information highlighting where our plan reflects meeting the 65% minimum threshold for the employee paid portion of the plan for GOED to independently confirm the same.

Robert Knuepfer

Name of person authorized for signature



Signature

President

Title

9/22/2023

Date

5(D) Company Information

Company Name: Bauderer Packaging LLC

County: Clark

Section 1 - Company Interest List

Directions: Please provide a detailed list of owners and/or members of the company. *The Governor's Office of Economic Development strives to maintain the highest standards of integrity, and it is vital that the public be confident of our commitment. Accordingly, any conflict or appearance of a conflict must be avoided. To maintain our integrity and credibility, the applicant is required to provide a detailed list of owners, members, equity holders and Board members of the company.*

(a) Name	(b) Title
Rob Knuepfer	President

Section 2 - Company Affiliates and/or Subsidiaries

Are there any subsidiary or affiliate companies sharing tax liability with the applicant company? No Yes

If Yes, continue below:

Directions: In order to include affiliates/subsidiaries, under the exemption letter, they must to be added to the Contract. Per standard practice GOED requires a corporate schematic to understand the exact relationships between the companies. Please populate the below table to show the exact relationships between the companies and include:

1. The names as they would read on the tax exemption letter.
2. Which entity(ies) will do the hiring?
3. Which entity(ies) will be purchasing the equipment?

Name of Subsidiary or Affiliate Entity, Role and Legal Control Relationship

Please include any additional details below:

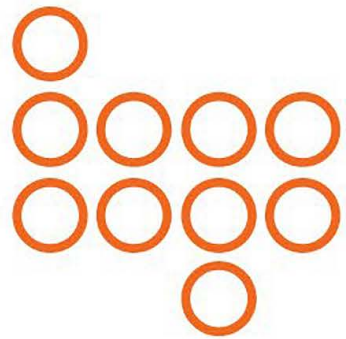

bauderer
PACKAGING

CANISTER LINE SET UP

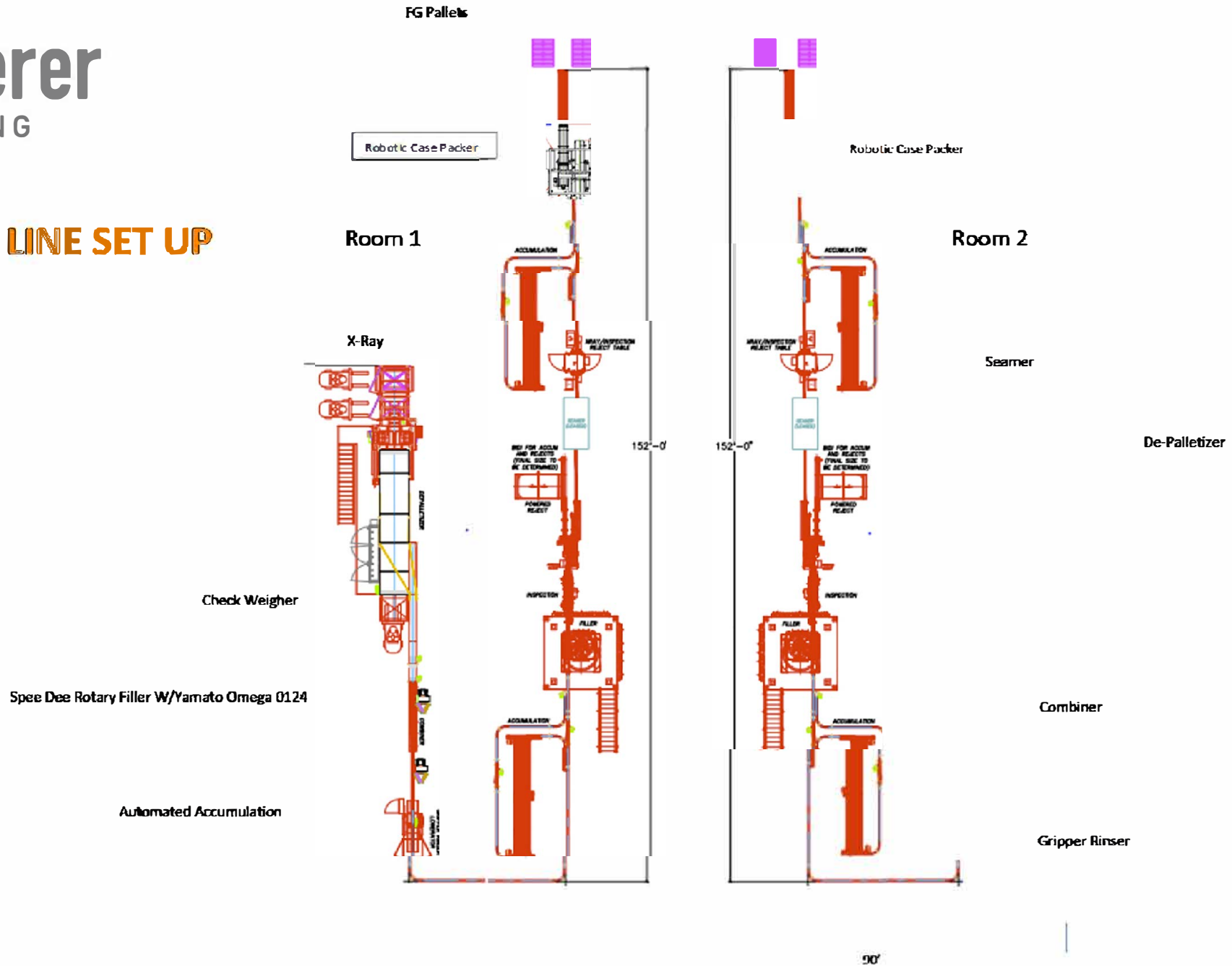

CANISTER LINE SET UP

A-B-C Can De-Palletizer

Yamato Omega 0124 Twin
Discharge Combination Weigher

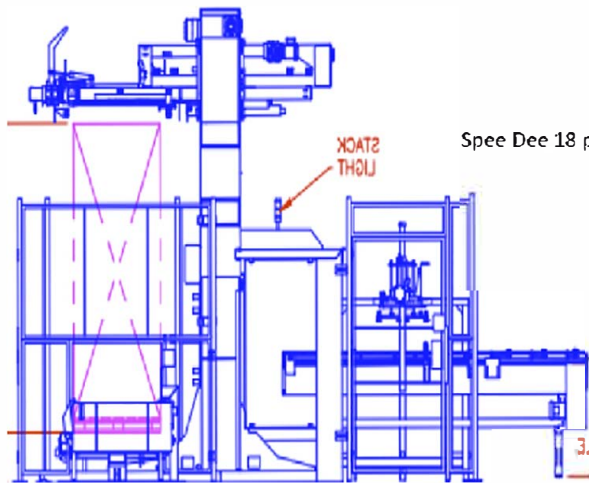

Spee Dee 18 pocket rotary filler

360-degree twist w/ air rinse

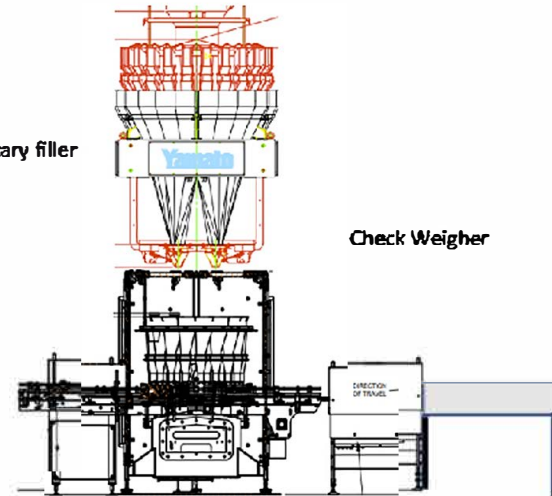

Check Weigher

Reject / Accumulation Area

A-B-C Robotic Case Packer

Seamer

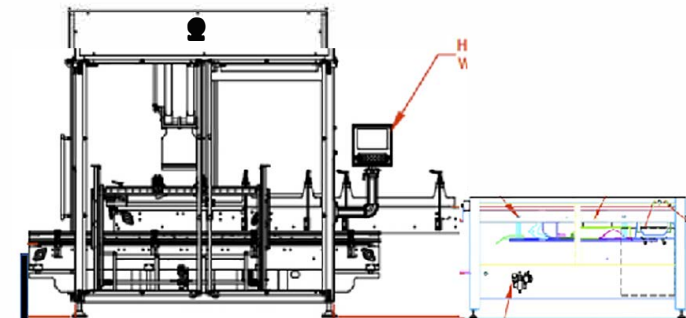

Sonoco Lease

A-B-C Case Sealer

X-Ray
Inspection

FG Pallet



CANISTER LINE KEY EQUIPMENT



Model 108 depalletizer

ABC packaging depalletizer
<https://www.abcpackaging.com/products/>



Spee Dee Rotary Filler & Comb Weigher
<https://www.spee-dee.com/rotary-fillers>

Nalbach Combiner & Accumulation Conveyor
<https://www.nalbach.com/products/>



Bauderer Packaging Capital Budget Estimate

<u>Description</u>	<u>Quantity</u>	<u>Cost (ea.)</u>	<u>Total</u>	<u>Serial #s</u>
Equipment				
Tote Tipppers	3	\$ 40,000.00	\$ 120,000.00	
Nalbach De-Pal system	3	\$ 833,604.00	\$ 2,500,812.00	
Custom Crossfeeder	3	\$ 25,000.00	\$ 75,000.00	
Scale Stands	3	\$ 25,000.00	\$ 75,000.00	
Yamato Omega 0214	3	\$ 261,000.00	\$ 783,000.00	
Spee Dee Rotary Filler	3	\$ 451,370.00	\$ 1,354,110.00	
Check Weigher 3 belt	3	\$ 45,000.00	\$ 135,000.00	
Thermo-Fischer X-Ray	3	\$ 188,000.00	\$ 564,000.00	
FIFO Accumulation Tables	3	\$ 269,500.00	\$ 808,500.00	
AFA Automated Case Packer	3	\$ 553,476.00	\$ 1,660,428.00	
Case Sealer	3	\$ 66,000.00	\$ 198,000.00	
Custom Conveyance	3	\$ 200,000.00	\$ 600,000.00	
Case Coders	3	\$ 13,000.00	\$ 39,000.00	
Spare Parts	3	\$ 40,000.00	\$ 120,000.00	
Morrison Inverter	3	\$ 102,200.00	\$ 306,600.00	
Custom Gas Flush	3	\$ 361,690.00	\$ 1,085,070.00	
Infrastrucure / Production Rooms Project Mgt / Installation	3	833,000	\$ 2,499,000.00	
Nalbach / CHSC	3	\$ 275,496.00	\$ 826,488.00	
TOTALS		\$ 4,583,336.00	\$ 13,750,008.00	
TOTAL		\$ 13,750,008.00		



Site Options for 200,000 square foot facility

1. Phoenix, AZ
2. Rancho Cucamonga, CA
3. Las Vegas, NV

Please see attached industrial real estate survey for each location.

